

# The effect of vegetative buffers on wind and dispersion of particulate matter around poultry barns

**Andreas Christen<sup>(1)</sup>, Daryll Pauls<sup>(2)</sup>, Shabtai Bittman<sup>(3)</sup>**

<sup>(1)</sup> Department of Geography, University of British Columbia, Vancouver, BC, Canada

<sup>(2)</sup> Atmospheric Science Program, University of British Columbia, Vancouver, BC, Canada

<sup>(3)</sup> Agri-Food Canada, Agassiz, BC, Canada

# Motivation

Controlling emissions of particulate matter from poultry facilities is desirable to mitigate negative impacts on natural resources (air and water pollution), agricultural plots, animal and human health.

Vegetative buffers can possibly ‘filter’ emitted particulate matter and reduce total emissions leaving a property.



# Density of facilities in the Lower Fraser Valley



# Airflow of a typical 2-barn layout

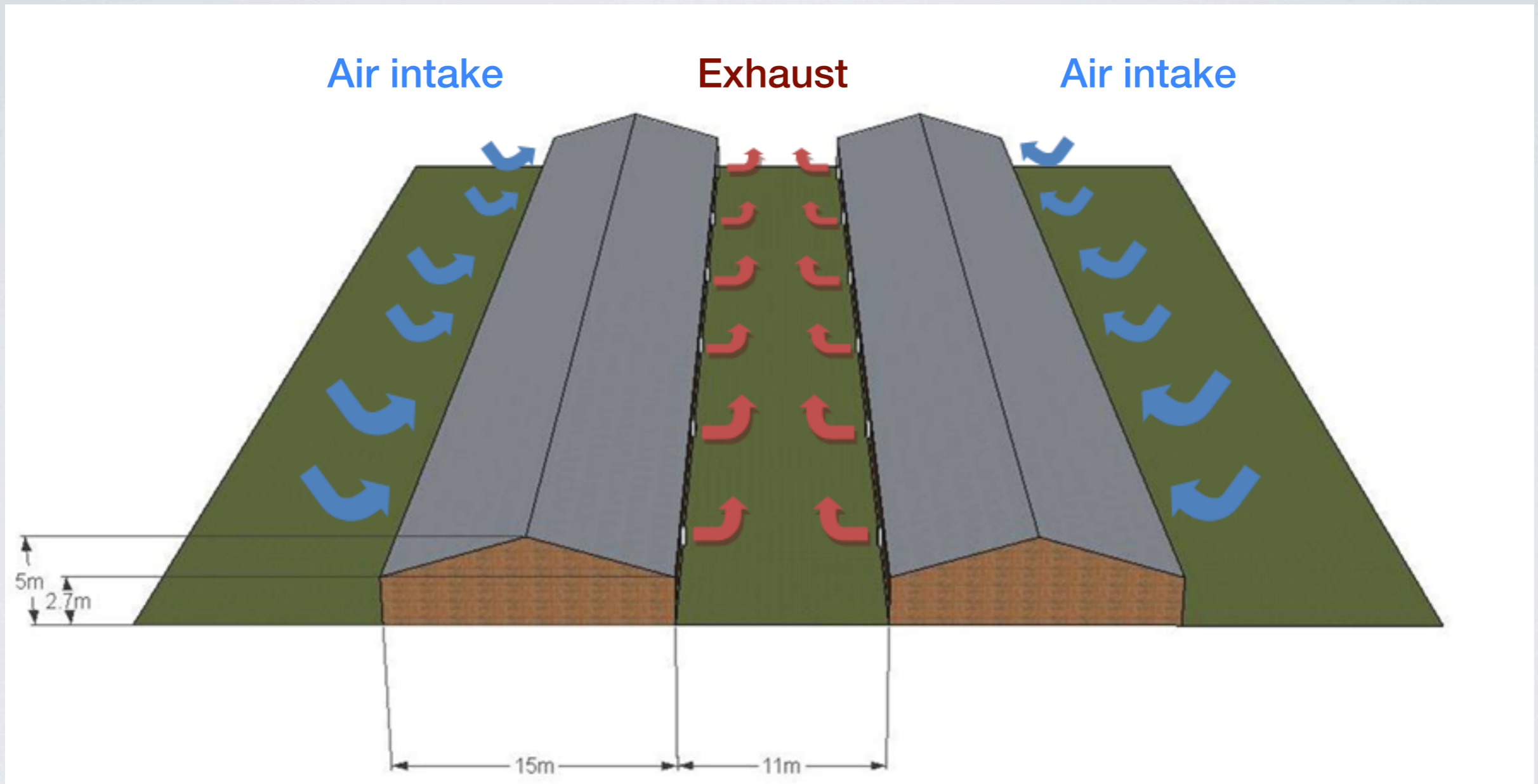

## Without vegetative buffer

Flow is accelerated between barns.

The emitted particulate matter is quickly dispersed and carried away.

## With vegetative buffer

Wind speed is slowed, mixing is reduced causing locally higher concentrations.

High concentrations of particulate matter means higher probability of deposition on leaves and ground. However, boundary layer resistances are also higher, reducing deposition rates.

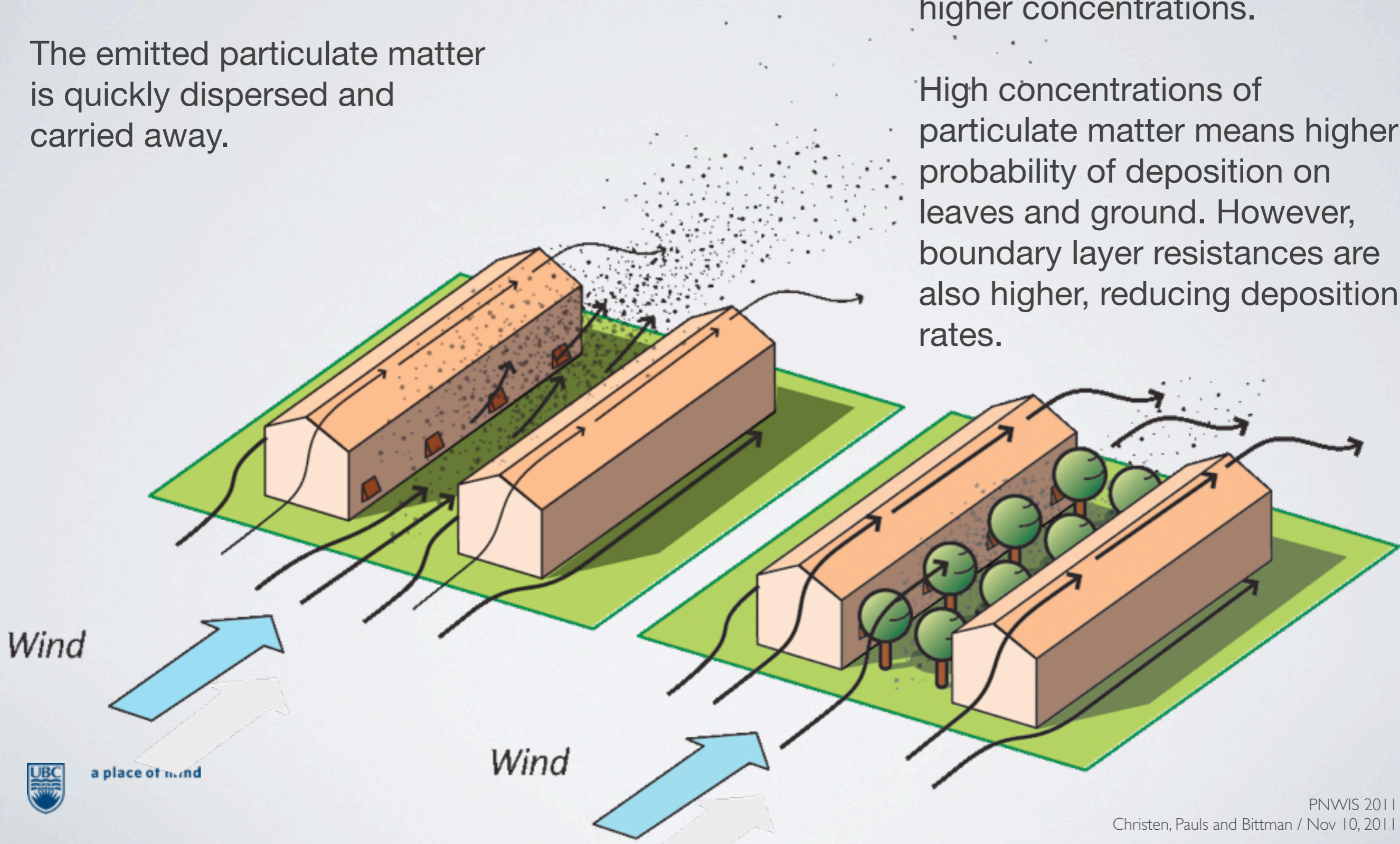

Wind

Wind



a place of mind

# Research questions

- What is the **potential of vegetative buffers** to remove particulate matter before it leaves a property?
- What would be most **efficient buffer layouts** that promote the removal of particulate matter - arrangement, height and density?



# Layout considerations for vegetative buffers

## In-fill of alleyway

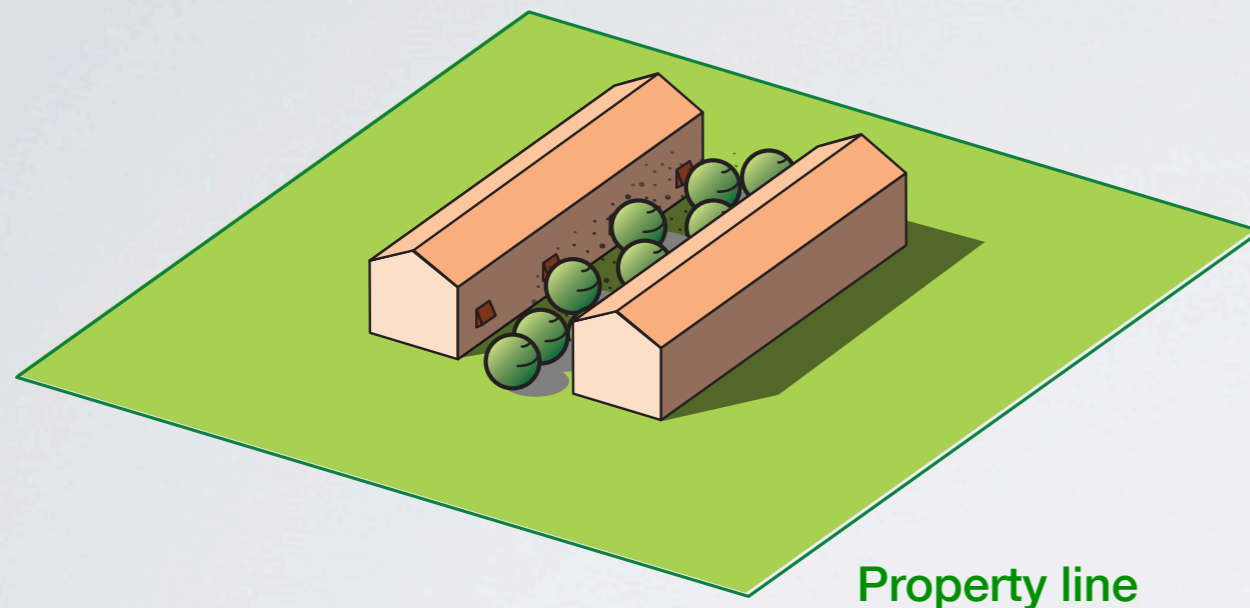

+ Vegetation removes particulate matter where concentrations are highest, i.e. close to source.

+ Moderate costs and maintenance.

- Complicates operation (access to alleyway)

## Perimeter

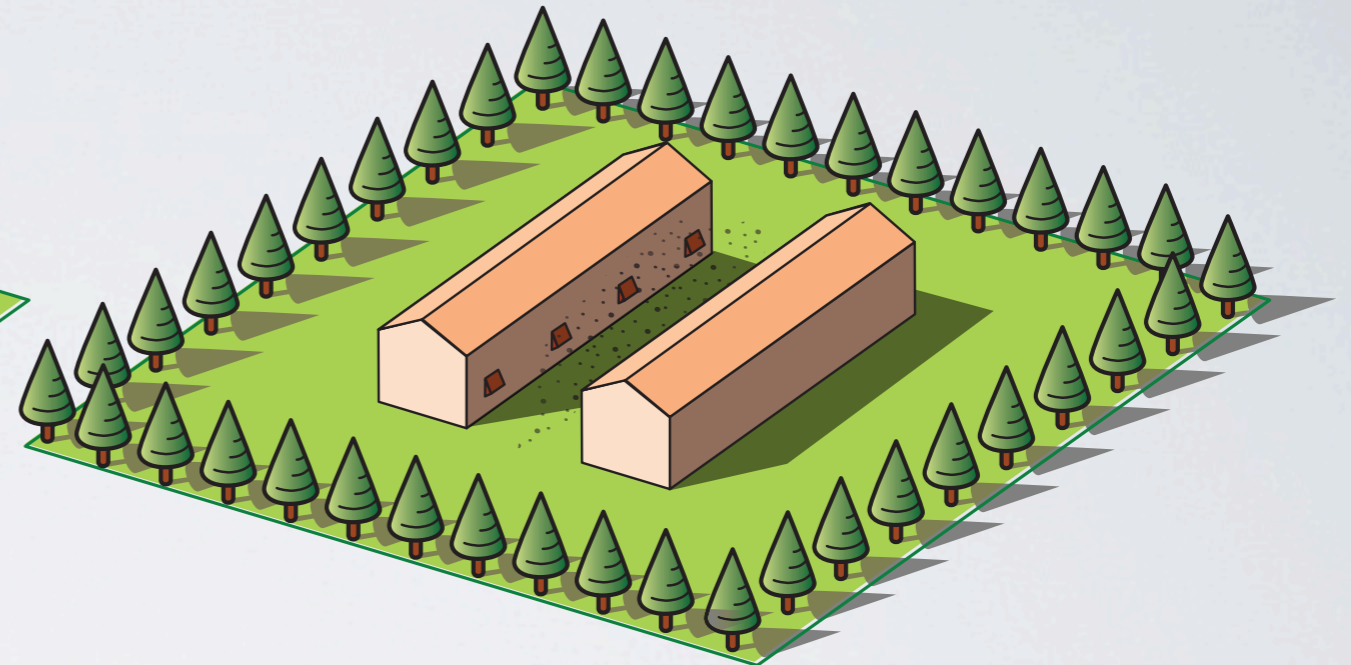

- Removes particulate matter downwind of facility, where concentrations are presumably lower.

- Substantial costs and water need.

+ Acts also as noise and visibility barrier.

# Methods

- Numerical model runs using the microclimate model **Envi-met** (Version 3.1b5, Bruse 2010)
- Envi-met is a 3-d Eulerian CFD model that is designed to simulate interactions between surfaces, buildings and plants, and the air flow which may contain particulate emissions (PM10).
- Modelled domain: 180 x 120 x 30 grid cells at a grid resolution of 1.5 x 1.5 m horizontally.





# Model runs

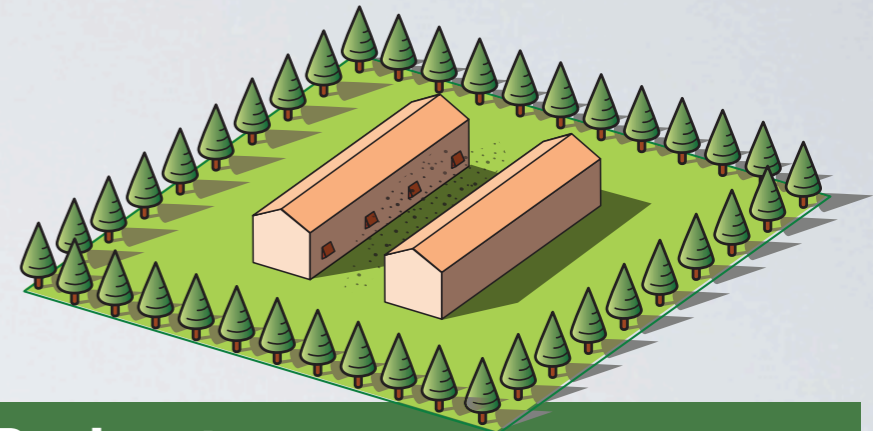
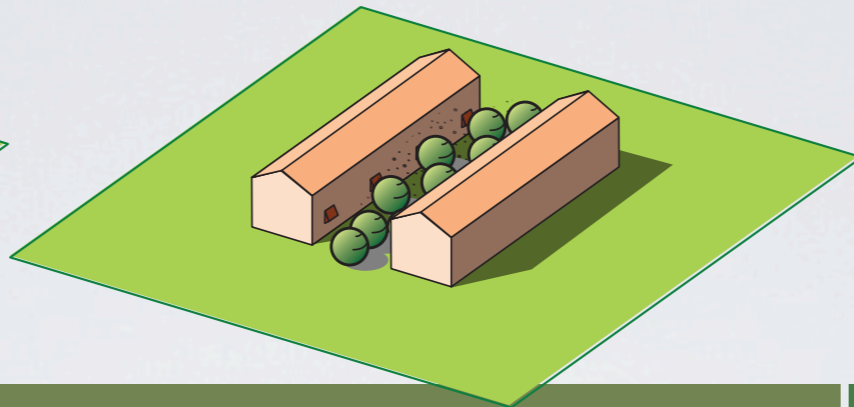
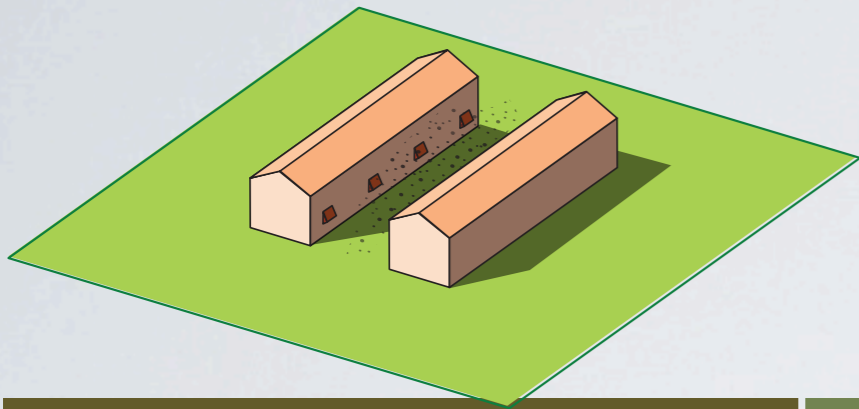

Reference	In-fill of alleyway	Perimeter
<p><b>R</b></p> <p>Neutral stability</p> <p>1.7 m/s wind at 1.5 m</p> <p>6 x 2 PM10 sources of 10 mg s<sup>-1</sup> on each side of alleyway at 1.5 m height</p>	<p><b>I1</b></p> <p>2m tall staggered shrubs with a plan area density of 13% (300 m<sup>3</sup> vegetation)</p>	<p><b>P1</b></p> <p>6m tall coniferous hedge, 15m away from edges of barn (6,000 m<sup>3</sup> vegetation)</p>
	<p><b>I2</b></p> <p>Same as I1 with only 1/3 leaf area density (300 m<sup>3</sup> vegetation)</p>	<p><b>P2</b></p> <p>Same as P1 but 30m away (8,000 m<sup>3</sup> vegetation)</p>
	<p><b>I3</b></p> <p>Same as I1 but 6m tall (900 m<sup>3</sup> vegetation)</p>	<p><b>P3</b></p> <p>Same as P2 but 15m tall (24,000 m<sup>3</sup> vegetation)</p>

# Effect of perimeter buffer on wind speed (P1)

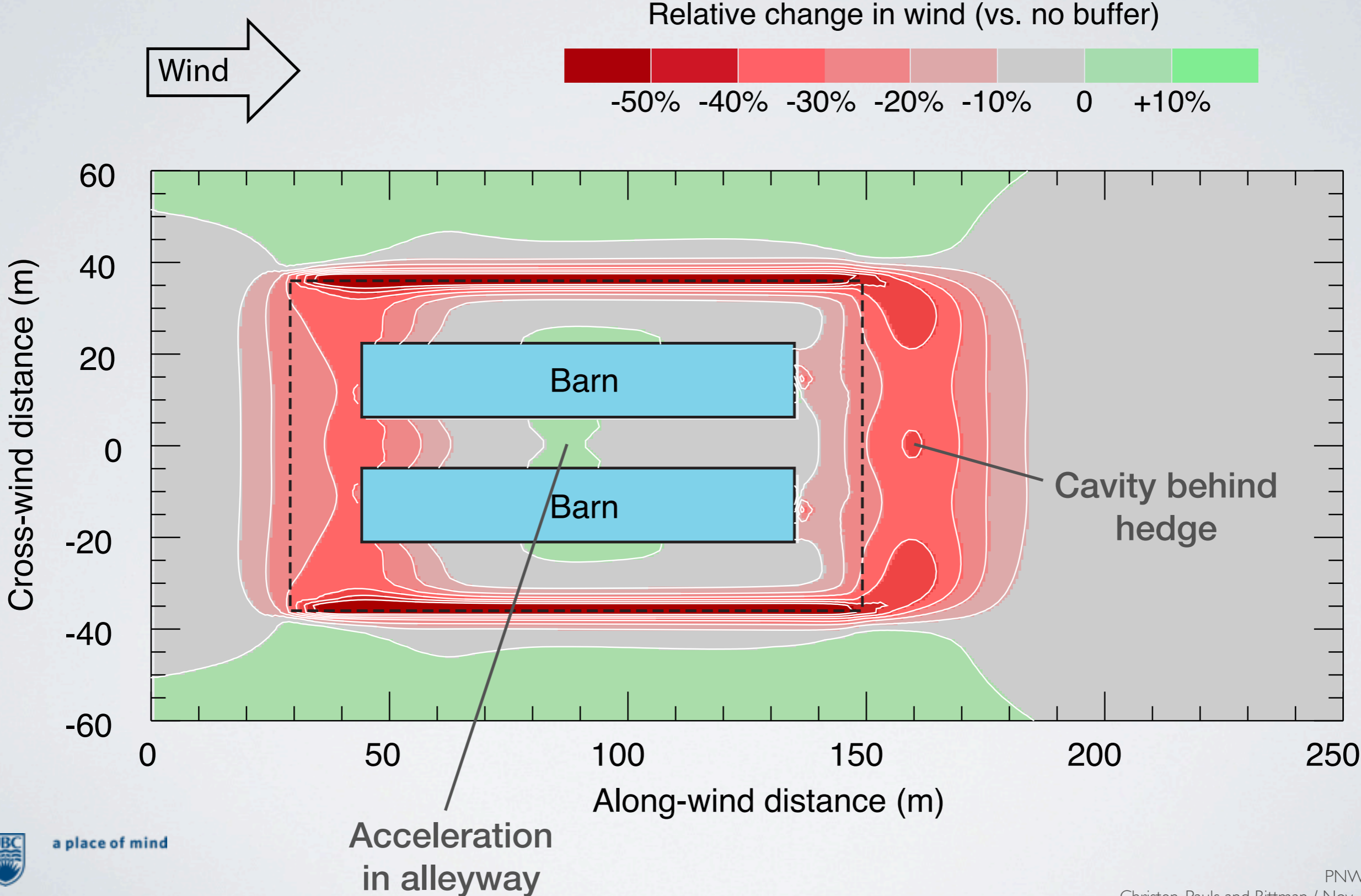

# Effect of in-fill buffer on wind speed (I1)

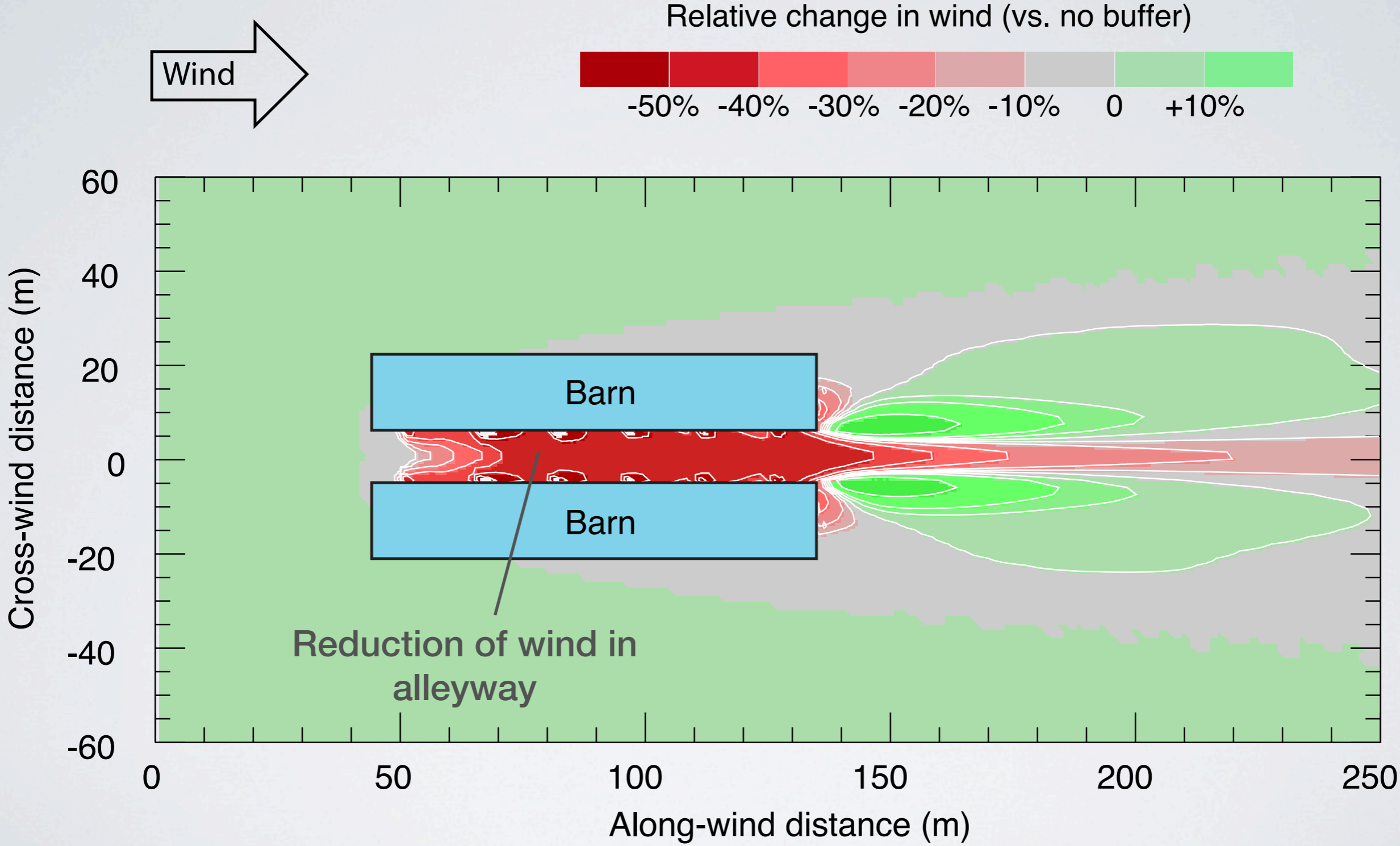

# Effect of buffers on wind speed

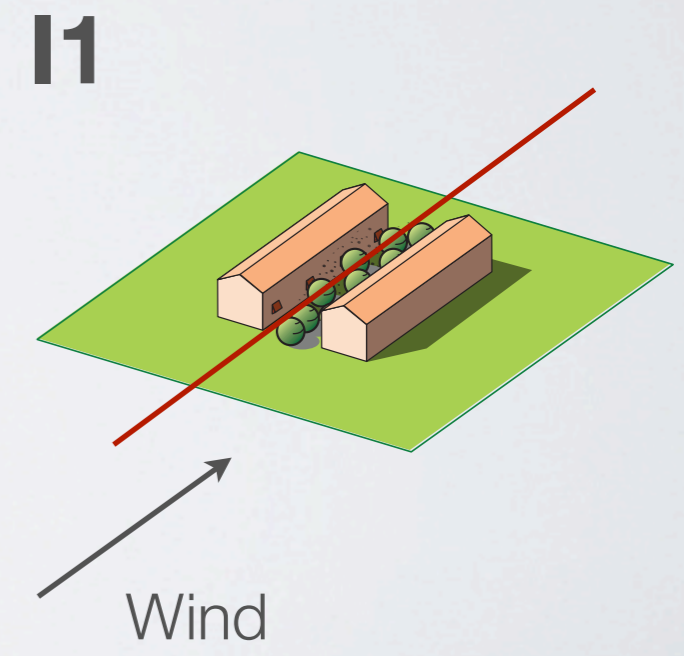
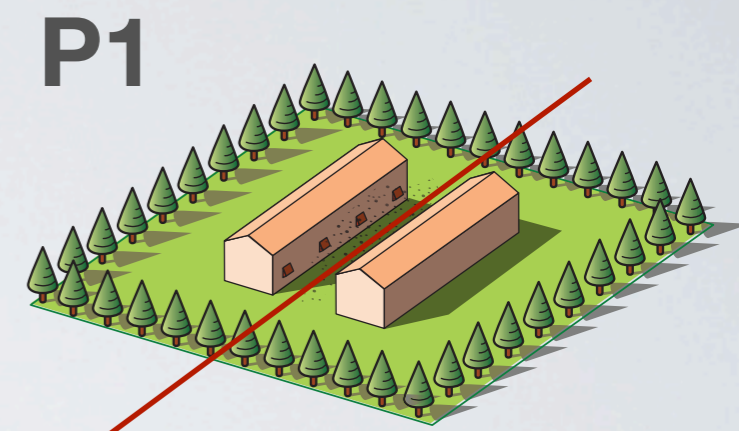
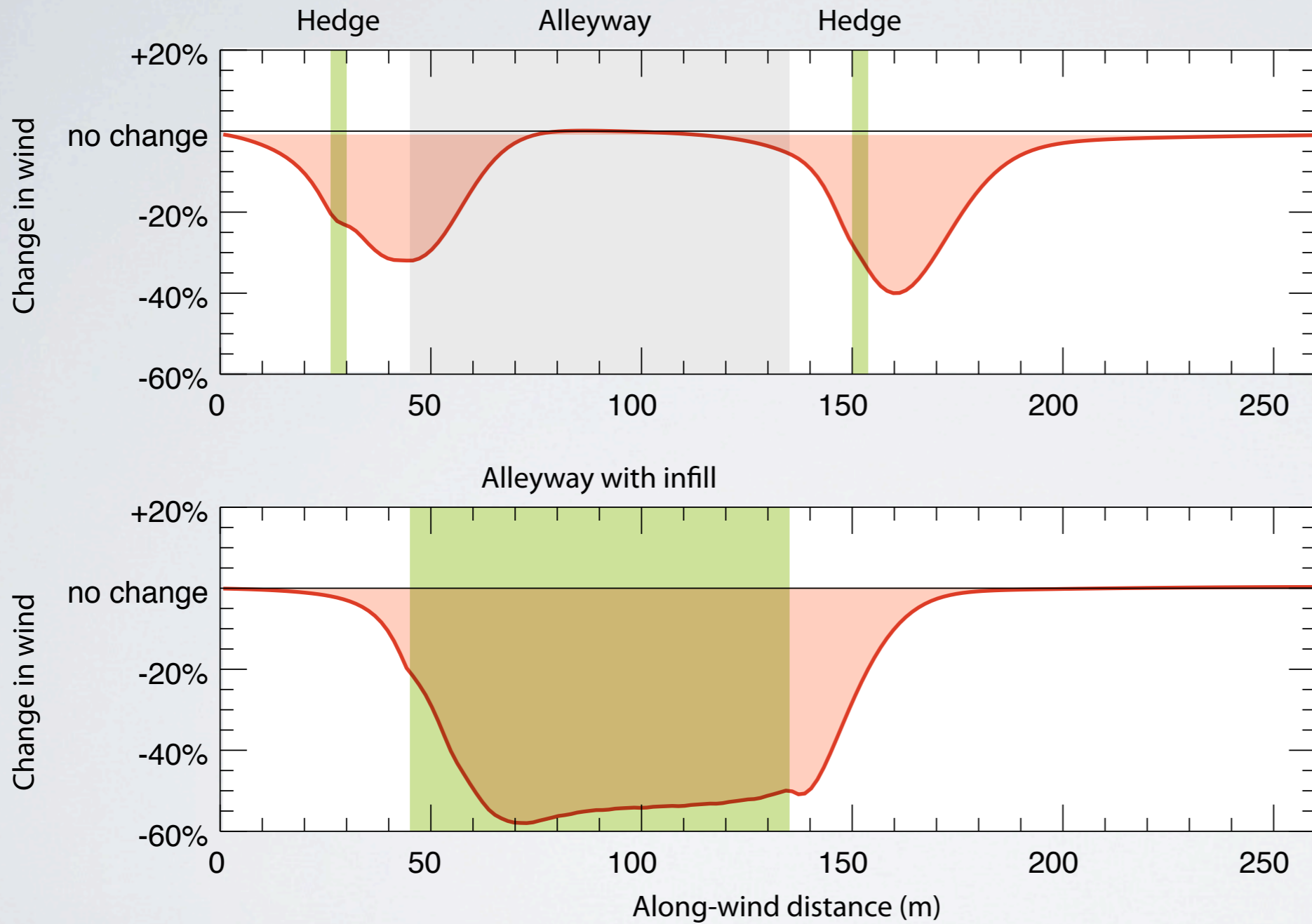

# Modelling PM10 Concentrations

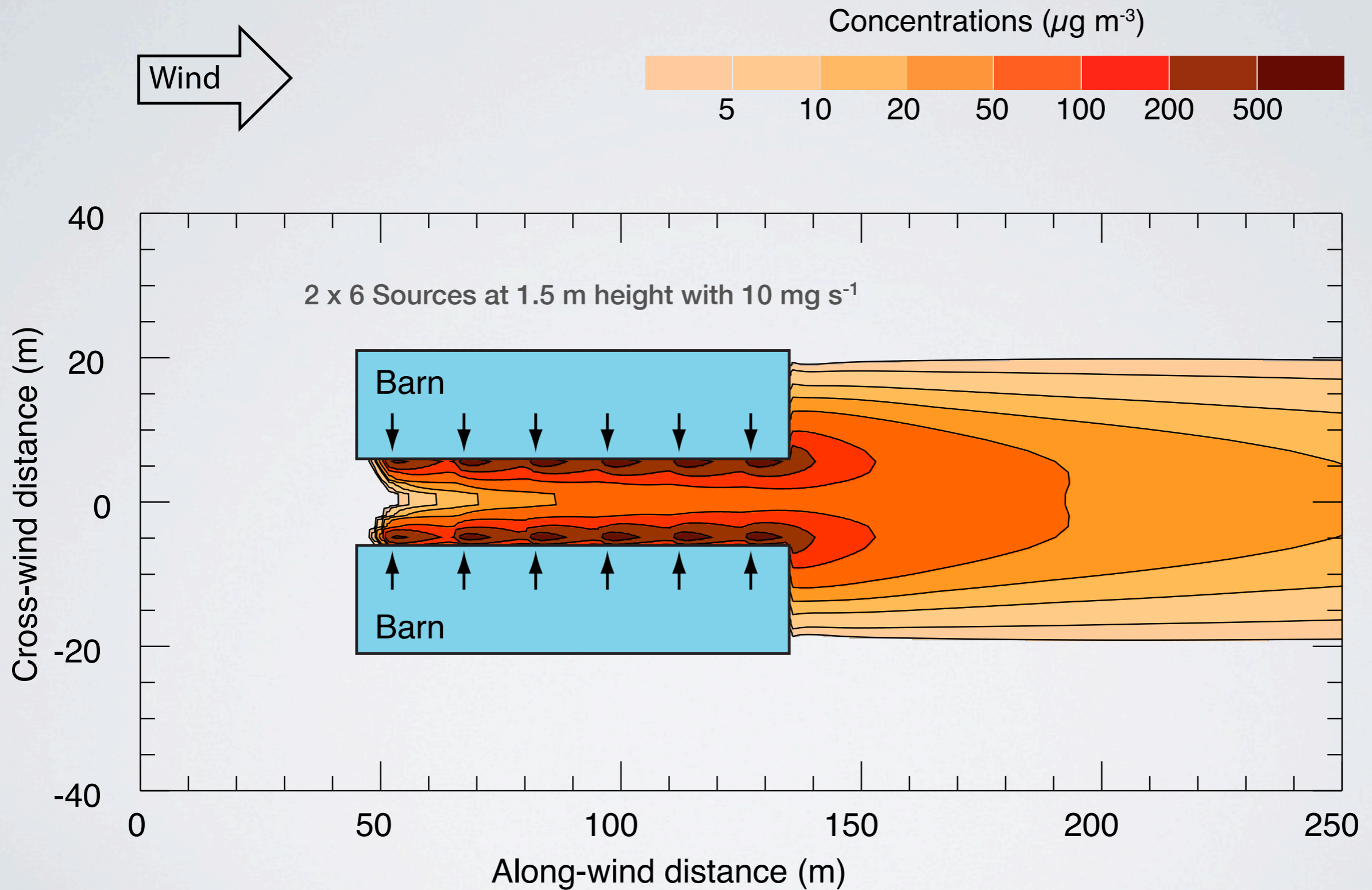

# Effect of buffer on PM10 concentrations

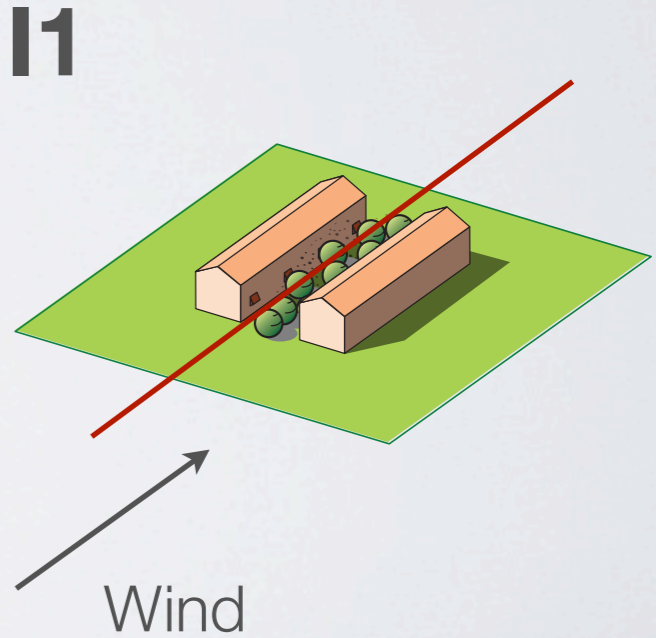
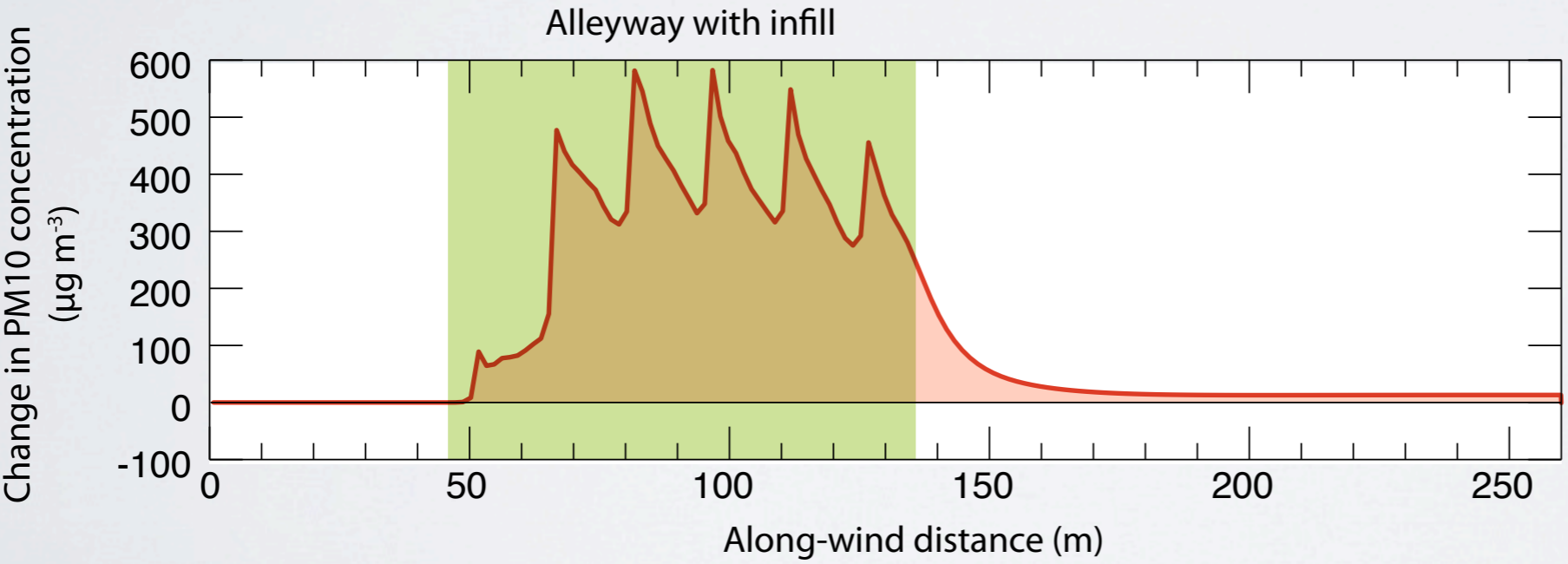
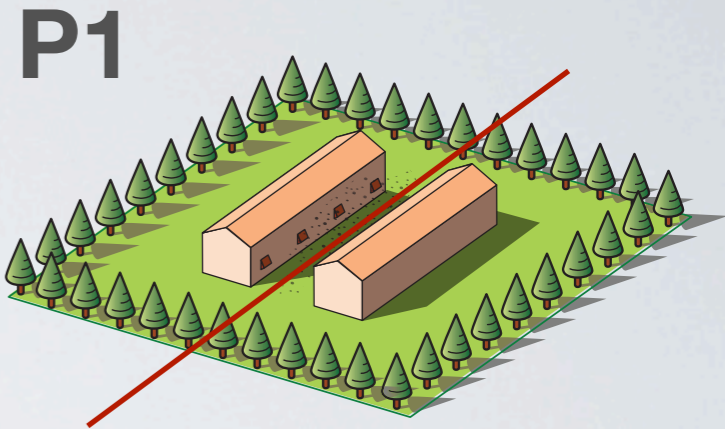
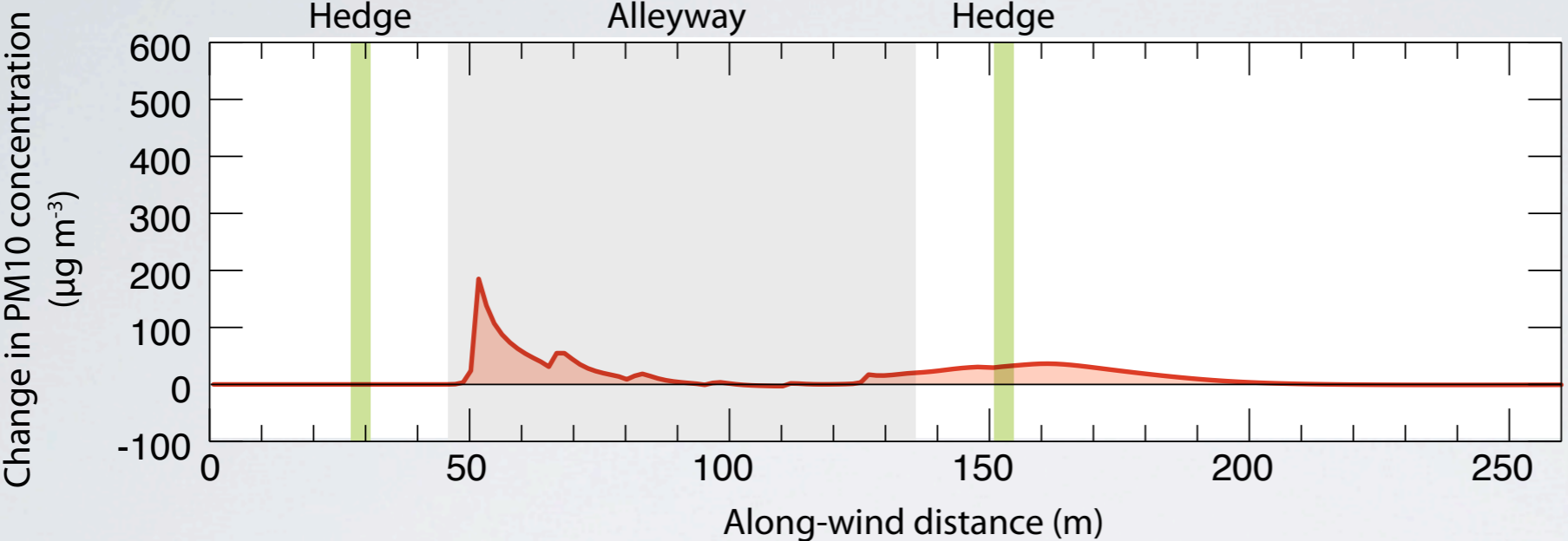

# Change in PM10 concentration in alleyway

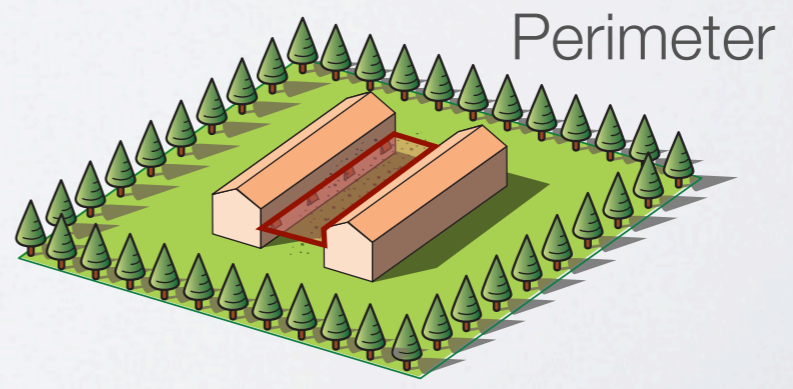
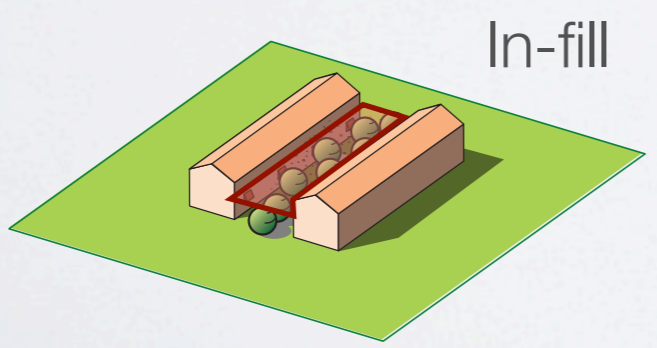
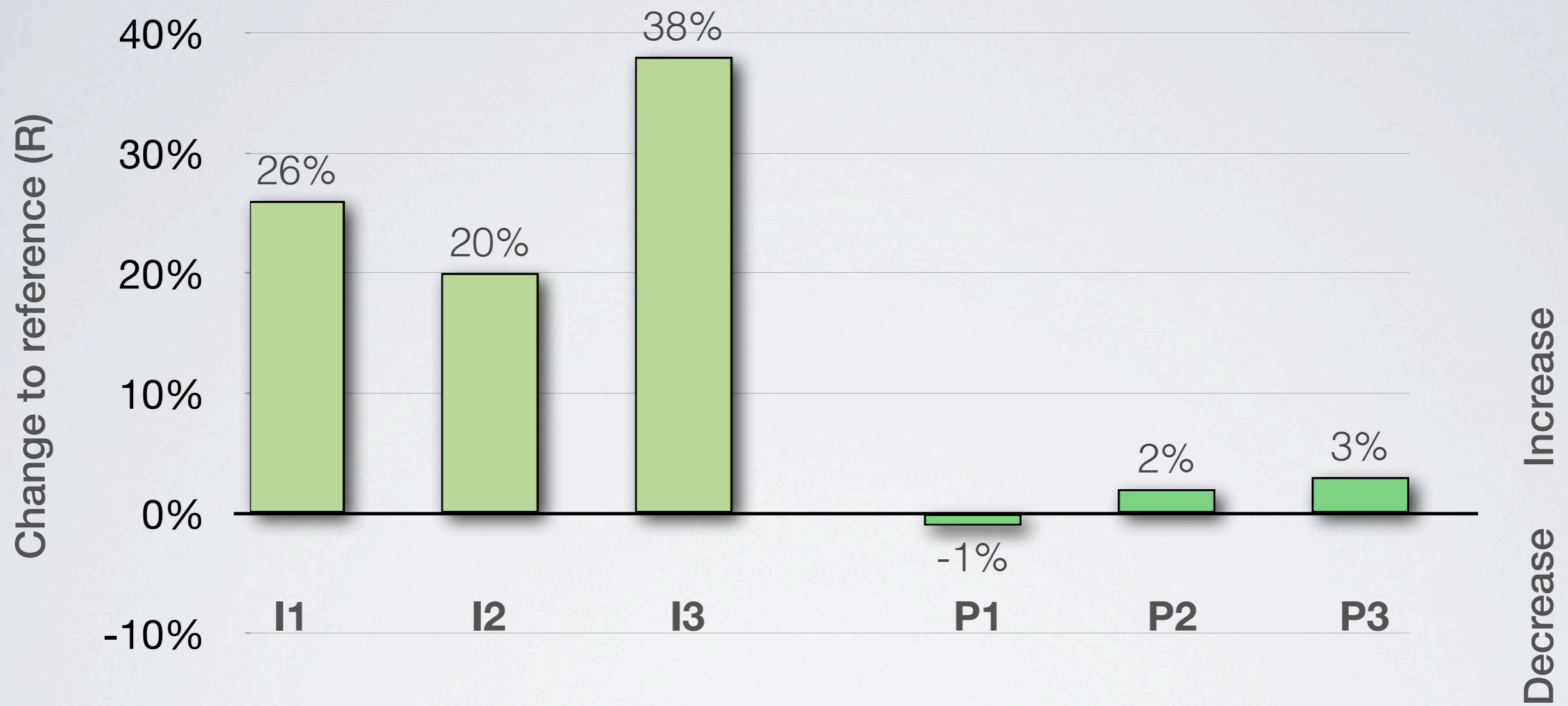

# Effect of leaf area density

In-fill only, average values in alleyway at 1.5 m above ground

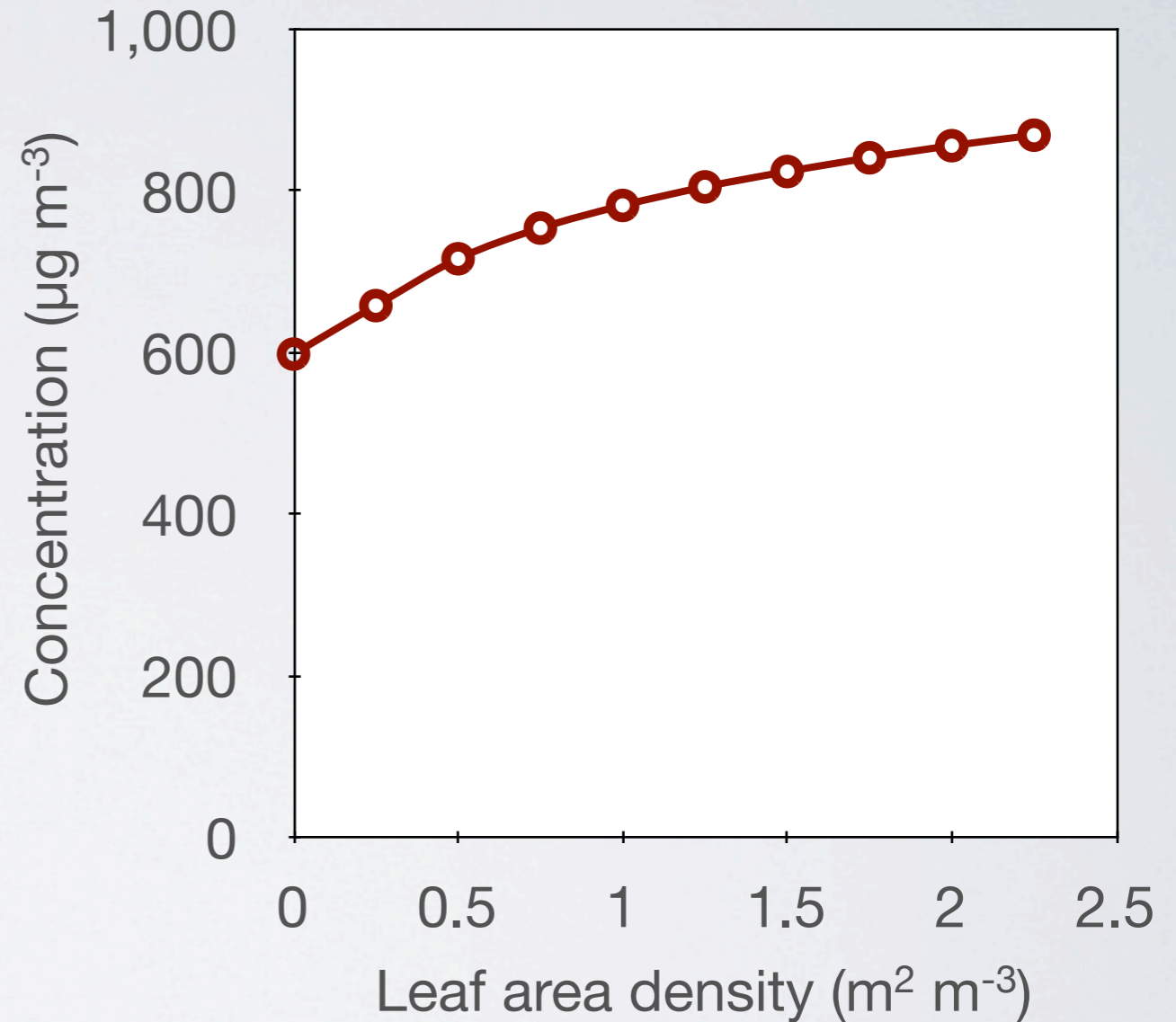
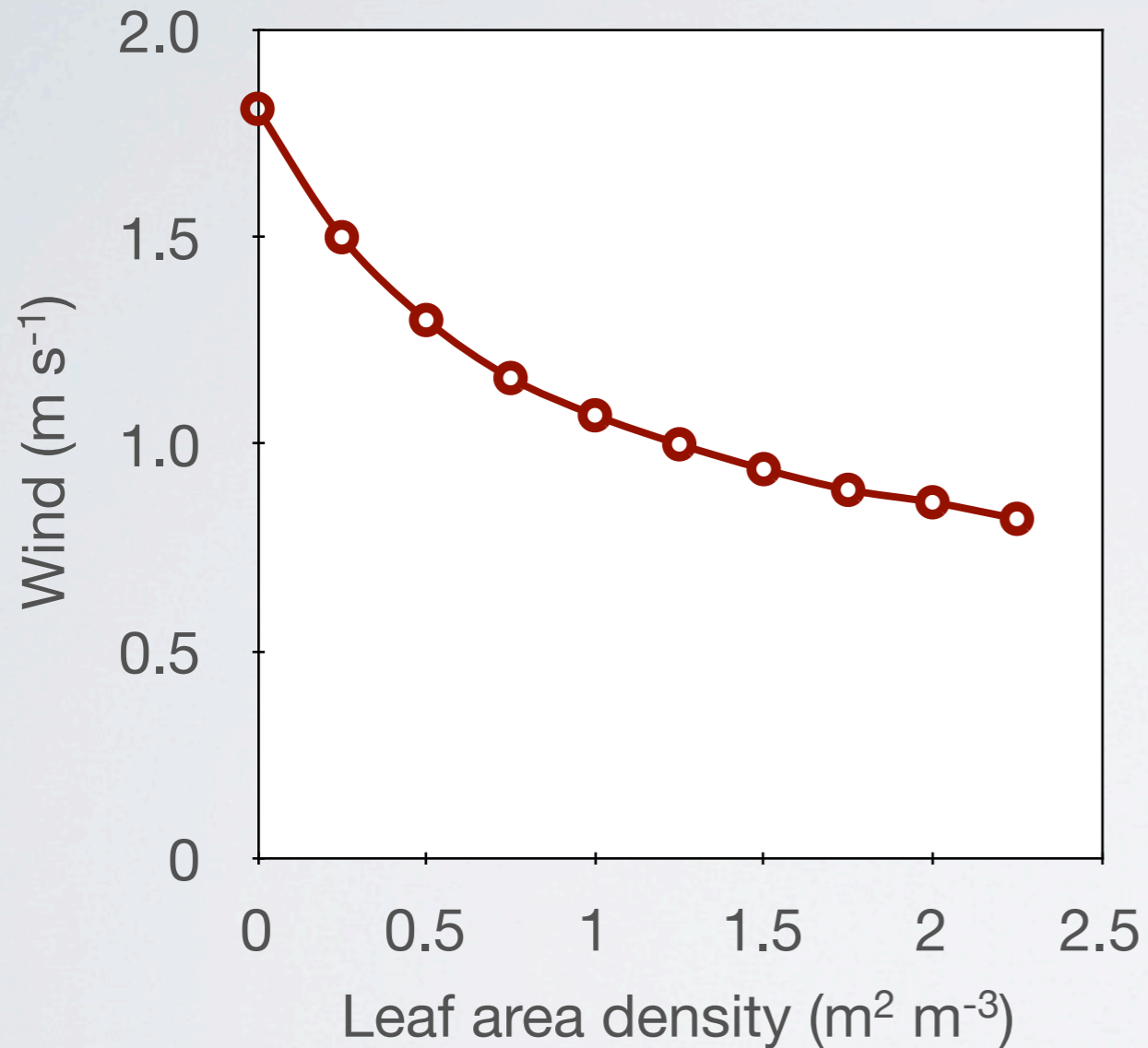

In-fill

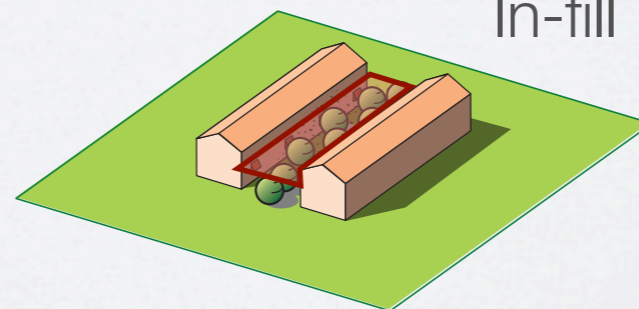



# Total deposition of PM10

on ground, vegetation and roofs

## Reference

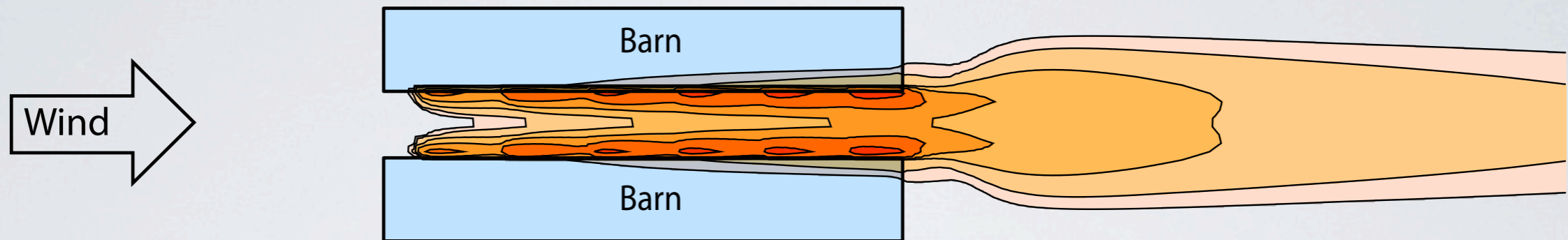

## P1

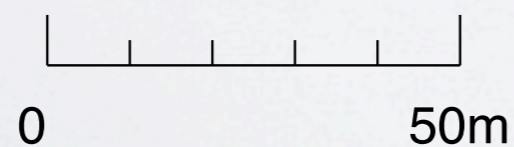
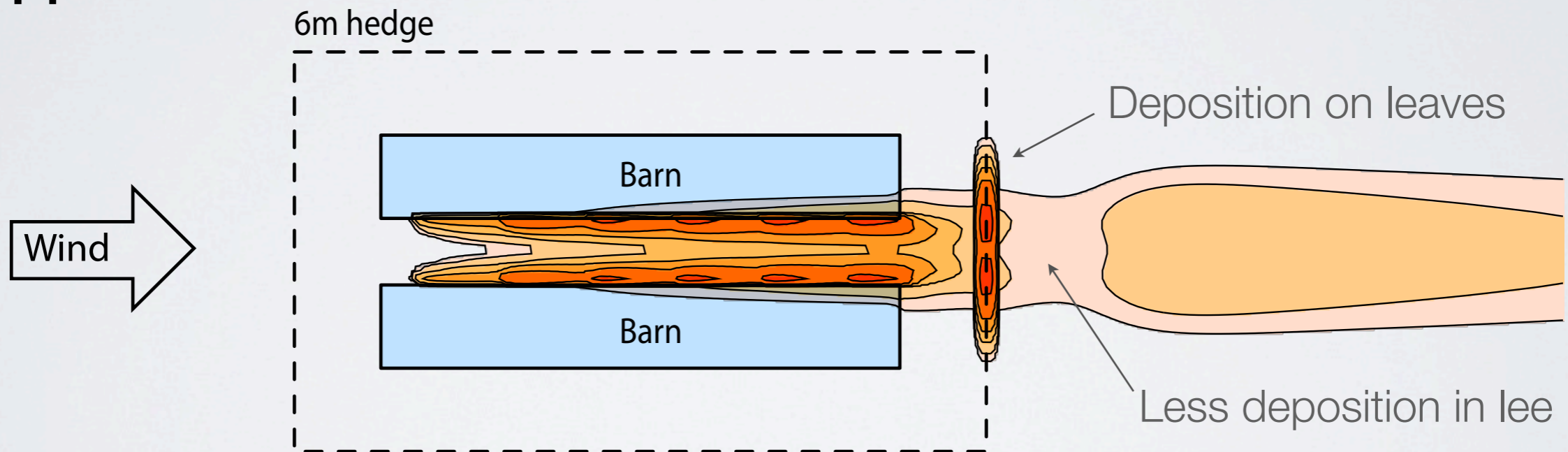

Total PM10 deposition

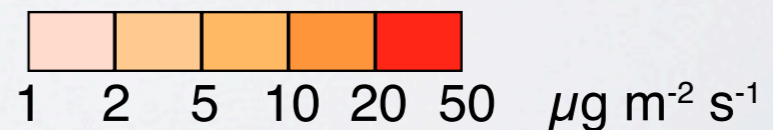

# PM10 removal by vegetation

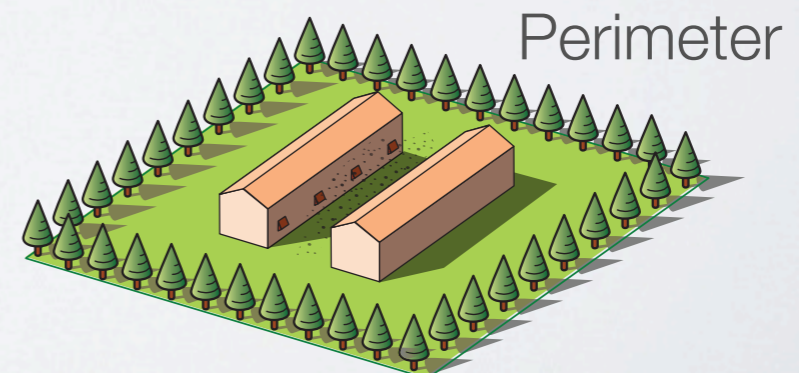
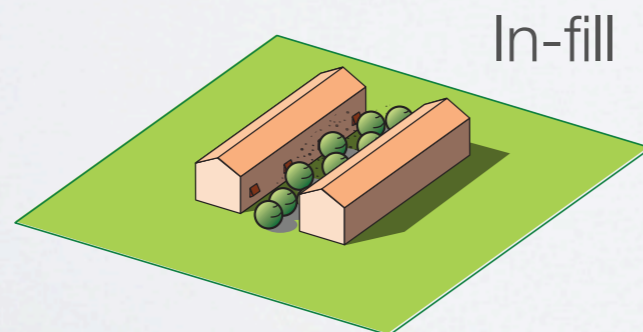
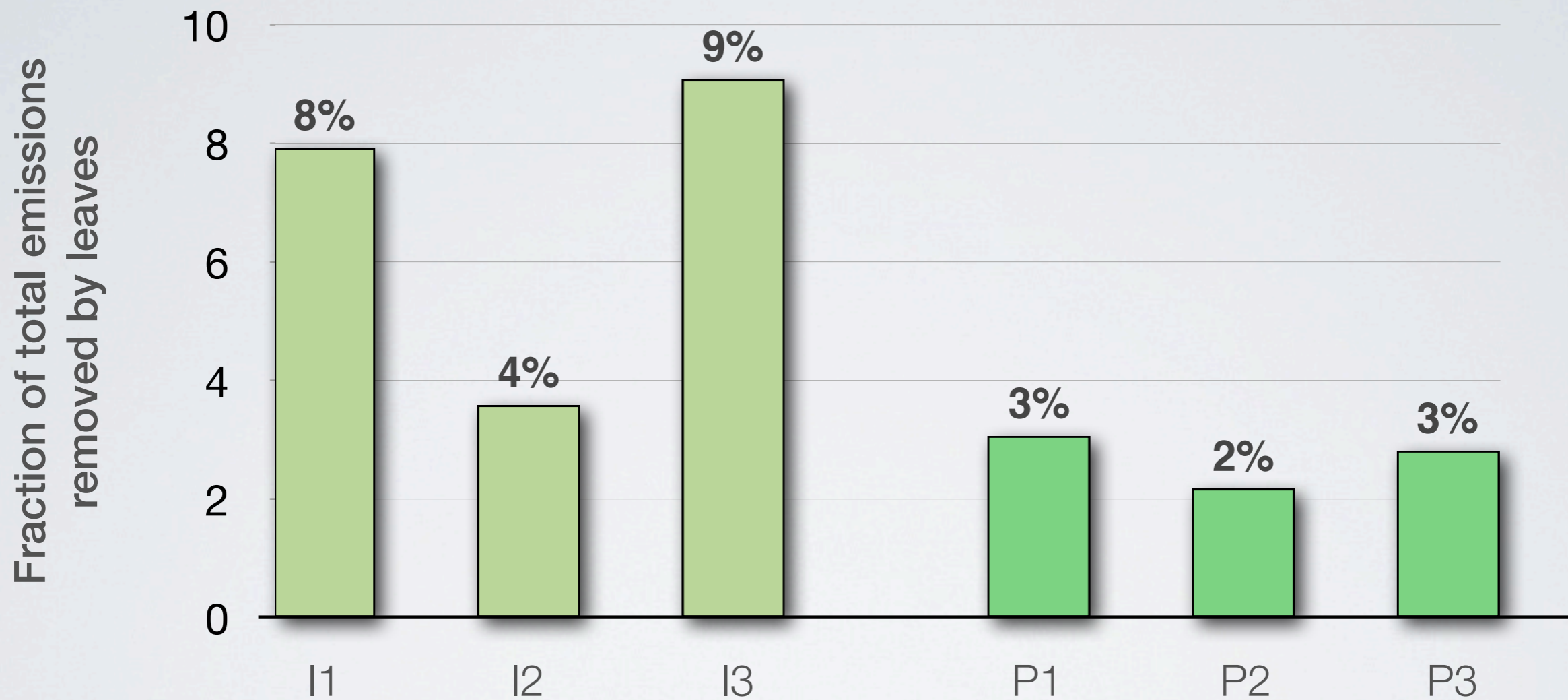

# Cross-wind integrated PM 10 deposition

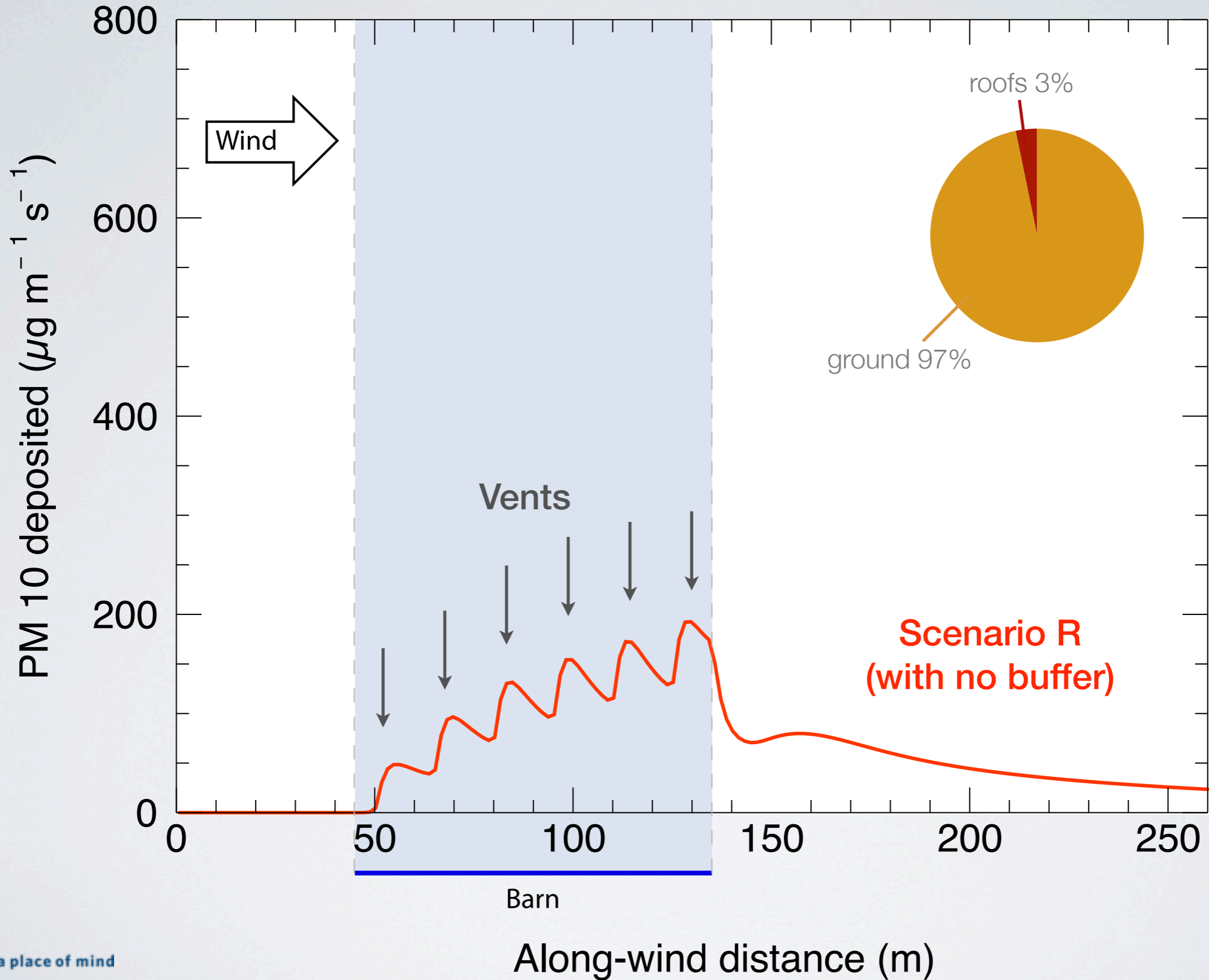

# Cross-wind integrated PM 10 deposition

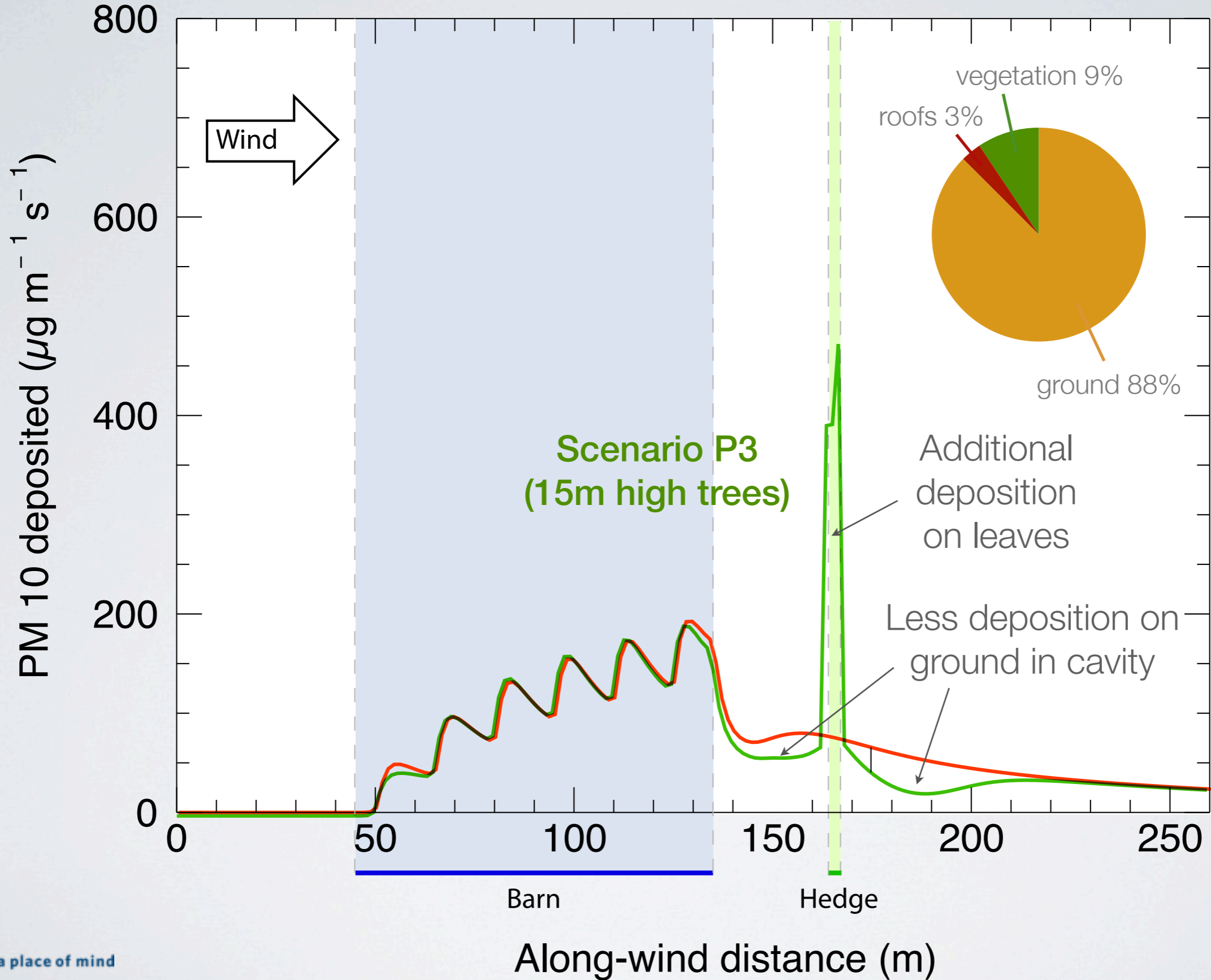

# Fraction of PM10 emitted that is removed before leaving the property

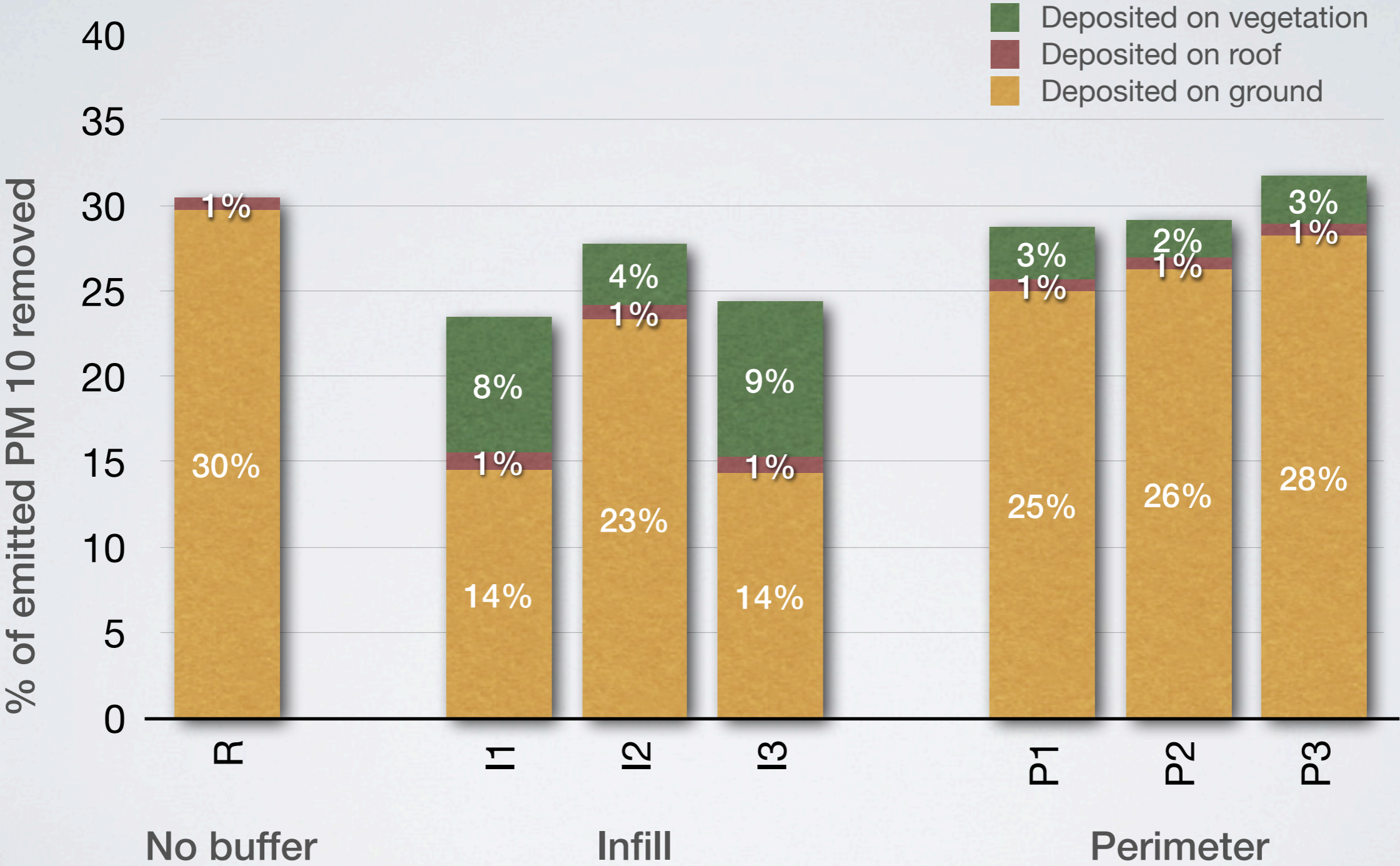

# Summary

- As expected, vegetative buffers **decrease wind** and consequently **increase concentrations** (desired).
- Perimeter layouts show little to no impact. More efficient to modify wind and dispersion is an **infill of the alleyway**.
- In the best case, **up to ~10%** of emitted PM10 was **deposited on the buffer**.
- In none of the scenarios, total PM10 leaving the property was significantly reduced. In some cases the enhanced deposition on leaves **was offset by much reduced deposition on ground** behind buffer elements.

